



RIGHT STUFF EQUIPMENT

ROTARY UNSCRAMBLING TABLE

Right Stuff Equipment Rotary Unscrambling Tables efficiently unscramble and align products without impacting upstream production.

Ideal for the unscrambling of:

- Round Glass Bottles and Jars
- Aluminum Cans and Bottles
- Plastic Tubs

Made in the USA. Denver, Colorado



STAINLESS STEEL
CONSTRUCTION

TECHNICAL SPECIFICATIONS

TABLE SIZES

36"

48"

60"

LINE HEIGHT	26" - 44"
CONTAINER TYPES	Rounds & Tubs
IP RATING	55
ELECTRICAL	120/240 VAC, 6.8A/3.4A Max Current Draw Single Phase, 60Hz
FOOTPRINT	Table Size Dependant
WEIGHT	250 lbs
WARRANTY	1 Year

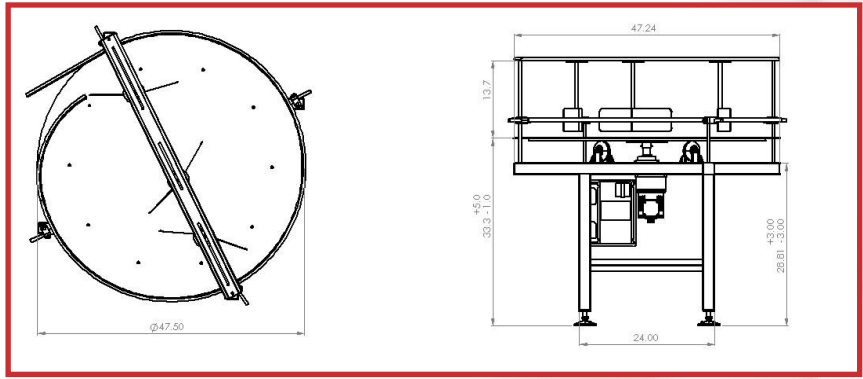

FEATURES

- Stainless Steel Tube Frame
- Nema 4X VFD with Rotary Disconnect Switch
- Embedded I/O for Automatic Line Control
- 1/8 HP Rated Gearmotor
- Rated for use in Wet Food and Washdown Environments
- Adjustable Table Speed (1-10RPM)
- 200 LB Max Table Capacity
- Shear Pin Coupling to Prevent Motor Overload
- Heavy Duty Aluminum Support Plate
- 10 Gauge Heavy Duty Stainless Steel Top
- Adjustable Stainless Steel Paddles for Product Orientation
- Clockwise/Counterclockwise Table Rotation
- Standard Adjustable Line Heights from 26" - 44"

OPTIONS

- Stainless Steel Total Locking Casters
- Double Guide Rails for Tall Products
- Custom Heights Available
- Other Voltage Options Available
- UHMW Transfer Shoe for Side Transfer onto Conveyor
- Integrated Loading Shelf

RIGHT STUFF EQUIPMENT

1605 E. 69TH AVENUE
DENVER, CO 80229

PHONE: 303.327.4704

FAX: 303.327.4708



WWW.RIGHTSTUFFEQUIPMENT.COM