



# RIGHT STUFF EQUIPMENT

## STANDARD ROTARY LIP STYLE ACCUMULATION TABLE

Right Stuff Equipment Rotary Accumulation Tables are a cost efficient way to collect products at the end of a production line, for pack off, inspection, or accumulation without impacting upstream production.

Ideal for the accumulation of:

- Cartons and small boxes
- Flexible film packaging

Made in the USA.



STAINLESS STEEL  
CONSTRUCTION

### TABLE MODELS

S-LT-36	36"
S-LT-44	44"

### TECHNICAL SPECIFICATIONS

- 120/240V Single phase input power
- 12A max current draw (Voltage dependant)
- NEMA 1/ IP40 DC Motor Controller
- IP 40 rated 1/7 HP rated gearmotor
- Rated for wet food environments
- Adjustable table speed (0-26 RPM)
- 150LB max table capacity

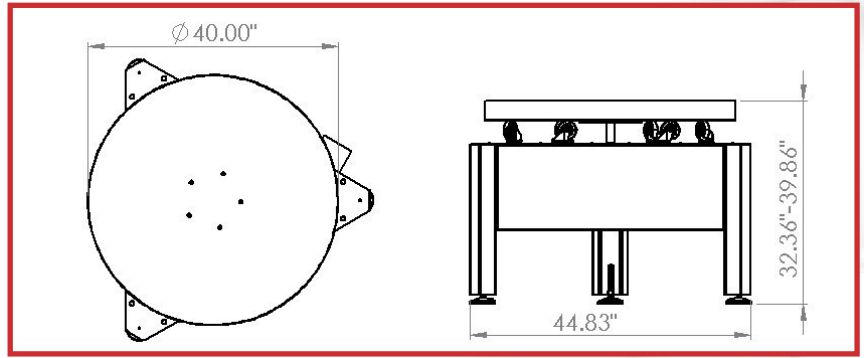

## FEATURES

- Stainless Steel bolted frame design
- 12GA Stainless steel top plate
- 3" Tall lip to contain products inside table
- Clockwise / counter-clockwise table rotation
- Standard adjustable line heights from 30"-37.5" from floor
- Adjustable machine feet for leveling and anchoring
- 1 year standard warranty

## OPTIONS

- Adjustable height stainless steel locking casters
- Double guide rails for tall products
- Custom lip heights available



RIGHT STUFF EQUIPMENT

1605 E. 69TH AVENUE  
DENVER, CO 80229

PHONE: 303.327.4704  
FAX: 303.327.4708



[WWW.RIGHTSTUFFEQUIPMENT.COM](http://WWW.RIGHTSTUFFEQUIPMENT.COM)

