



RIGHT STUFF EQUIPMENT PRODUCTS & SERVICES FOR THE THC/CBD MARKETS



BASED IN COLORADO

WE HAVE BEEN ACTIVELY ENGAGED IN THE AUTOMATION OF THE INDUSTRY





AUTOMATION PROCESS

**“RSE AND THC AUTOMATION DID A GREAT JOB ON OUR PACKAGING AUTOMATION PROJECT”
JOHN LORD- PRESIDENT OF LIVWELL**

- Evaluate Product Categories You Want to Participate in
- Make Projections on Sales Volumes
- Evaluate Automation Options to Achieve Throughput Most Efficiently
- Find a Partner to Help You with the Automation Process
- Make the Investment
- Get Started and Get Efficient





FLOWER/BUD WEIGH SYSTEMS

- Semi-Automatic to Fully-Automated Bud Weighment Lines
- Fast, Accurate, Affordable
- Scale
- Fill
- Label
- More
 - Pouches
 - Tubs
 - Cans with Nitrogen
 - Video

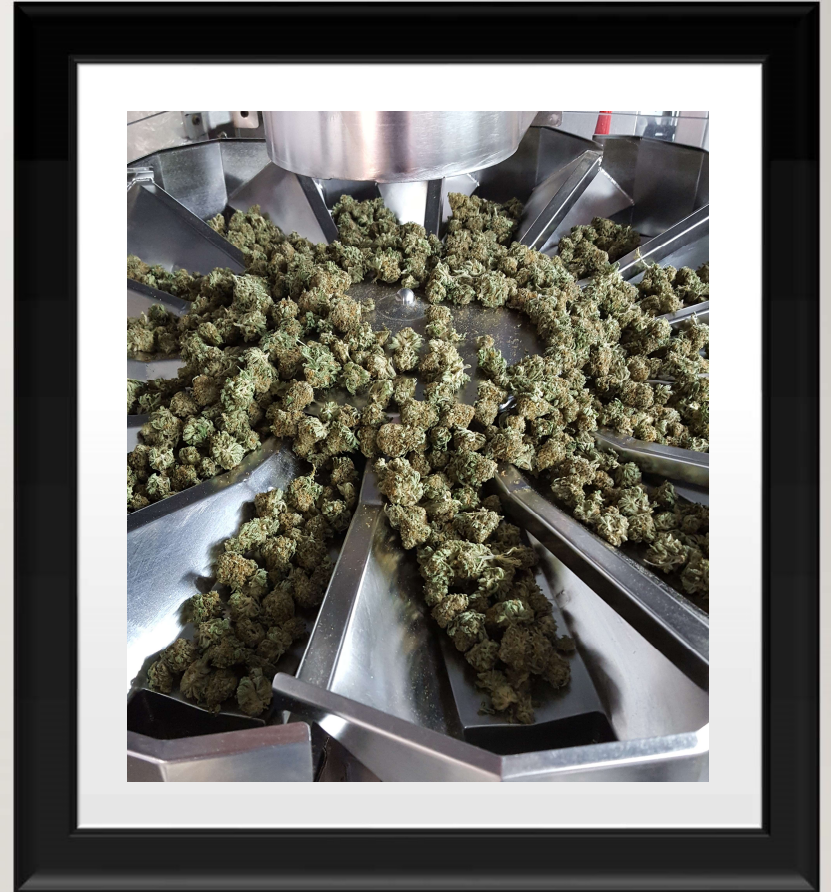



TUBS FOR FLOWER

- Scale
- Fill
- Label
- Code
- CR Caps
- Seal
 - All Sizes and Weights
 - Excellent Weight Control
 - High Speed





POUCH OPTIONS FOR FLOWER

VERTICAL POUCHES SINGLE USE



STAND UP ZIPPERED POUCH



RSE VERTICAL POUCH MACHINE



GP 3000 PMP POUCH MACHINE





FLOWER BULK PACKS LINEAR SCALES





INTEGRATED FLOWER PACKAGING LINES



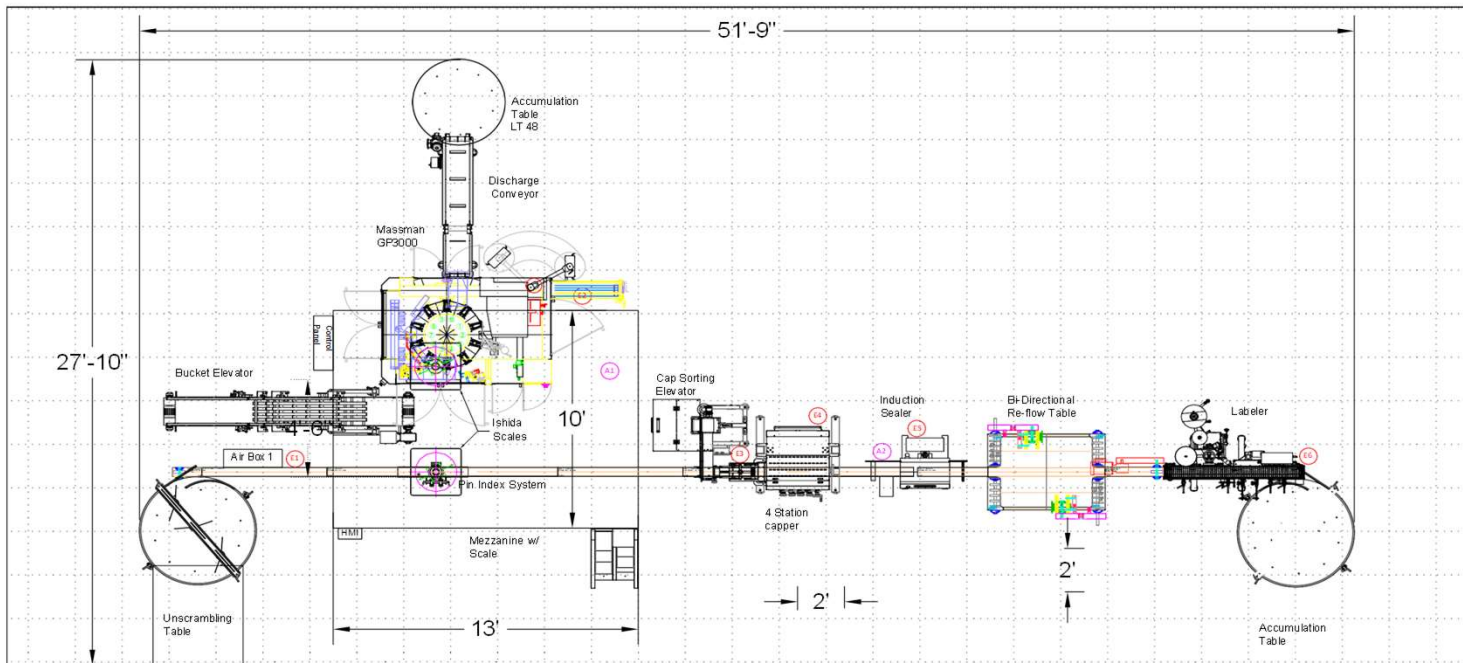

RIGHT STUFF EQUIPMENT

PROPRIETARY AND CONFIDENTIAL
 THE INFORMATION CONTAINED IN THIS DRAWING IS THE SOLE PROPERTY OF RIGHT STUFF EQUIPMENT. ANY REPRODUCTION IN PART OR AS A WHOLE WITHOUT THE WRITTEN PERMISSION OF RIGHT STUFF EQUIPMENT IS PROHIBITED.



DRAWN	F.V.	DATE	04/25/2019	MATERIAL	NA	CUSTOMER	ORESBYN	SIZE	B
CHECKED				FINISH	NA	JOB NUMBER	NA		
Q.A.				UNITS	Inches	ASSEMBLY	Bud Filling Line		
SCALE	DO NOT SCALE DRAWING			TOLERANCE	1/32	DWG NUMBER	05EVB01NK/1		REV
SHEET	SHEET 1 OF 1			LINEAR		PART NAME	PMP/BUD LINE		3
				ANGULAR					

5 4 3 2 1





LIQUID FILLING TABLE TOP OPTION PISTON, PERISTALTIC & GANTRY FILLING SYSTEMS





AUTOMATIC PISTON AND PERISTALTIC





SEMI AUTO & FULLY AUTOMATED LIQUID FILLING LINES



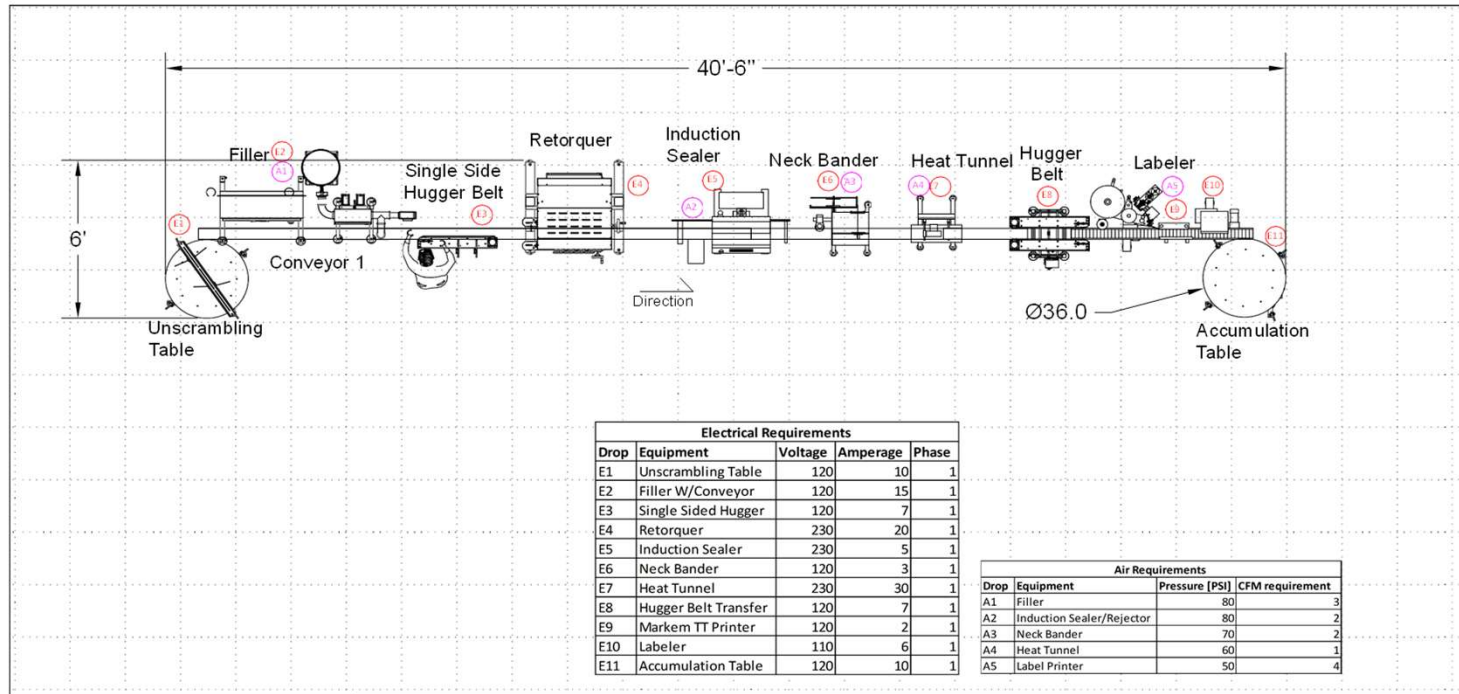

Electrical Requirements				
Drop	Equipment	Voltage	Amperage	Phase
E1	Unscrambling Table	120	10	1
E2	Filler W/Conveyor	120	15	1
E3	Single Sided Hugger	120	7	1
E4	Retorquer	230	20	1
E5	Induction Sealer	230	5	1
E6	Neck Bander	120	3	1
E7	Heat Tunnel	230	30	1
E8	Hugger Belt Transfer	120	7	1
E9	Markem TT Printer	120	2	1
E10	Labeler	110	6	1
E11	Accumulation Table	120	10	1

Air Requirements		
Drop	Equipment	Pressure [PSI] CFM requirement
A1	Filler	80 3
A2	Induction Sealer/Rejector	80 2
A3	Neck Bander	70 2
A4	Heat Tunnel	60 1
A5	Label Printer	50 4

RIGHT STUFF EQUIPMENT

PROPRIETARY AND CONFIDENTIAL
 THE INFORMATION CONTAINED IN THIS
 DRAWING IS THE SOLE PROPERTY OF
 RIGHT STUFF EQUIPMENT. ANY
 REPRODUCTION IN PART OR AS A WHOLE
 WITHOUT THE WRITTEN PERMISSION OF
 RIGHT STUFF EQUIPMENT IS
 PROHIBITED.



DRAWN	F.V.	DATE	03/18/2019	MATERIAL	NA	CUSTOMER	SeoTopt	SIZE	B
CHECKED		FINISH	NA	UNITS	Inches	JOB NUMBER		REV	1
SCALE	DO NOT SCALE DRAWING	TOLERANCE	1/32	DWG NUMBER	RAWIT-FRTL-WL	ASSEMBLY	Peristaltic Fill Line		
SHEET	SHEET 1 OF 1	LINEAR		PART NAME	TYPICAL LIQUID FILL LINE				

5

4

3

2

1





LIQUID FILLING LINES FOR TINCTURES

- Semi-Automatic to Fully-Automatic
- Typical: 5ml to 120ml
 - Unscramble
 - Fill
 - Label
 - Code
 - Eye Drop
 - Tamper Bands
 - Vape???





LOTIONS AND MOLTEN PRODUCTS

- Skin Care
- Topicals
- Molten Products

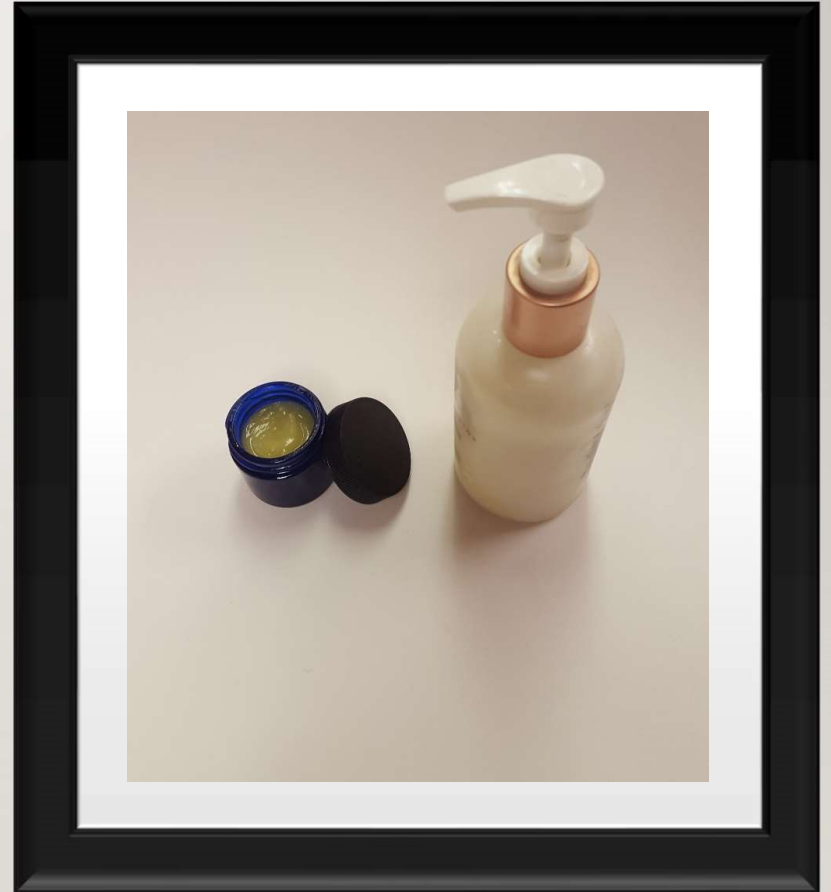



FULLY PROGRAMMABLE FOR CARTS, TINCTURES, MOLTENS





SOFT GELS, CAPSULES, TABLETS BLENDING, PLATING & SIZING

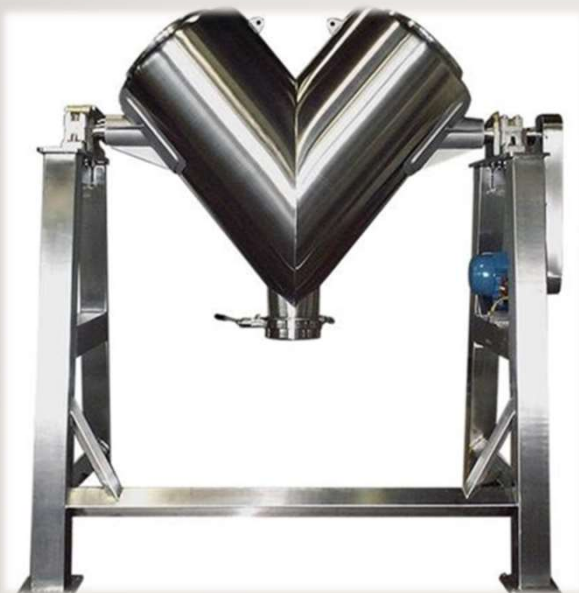



SOFT GEL, CAPSULES & TABLETS

- From Semi- Automatic to High Speed Lines
 - Capsules
 - Dry
 - Liquid. Soft Gel and 2 Piece Caps
 - Pressed Tablets
 - Coated
 - Non Coated
 - Mints
 - Bath Bombs
 - Counting Lines
 - Semi-Automatic to Automatic Filling. 10-150 bpm
 - Labeling
 - Coding
 - Capping
 - More

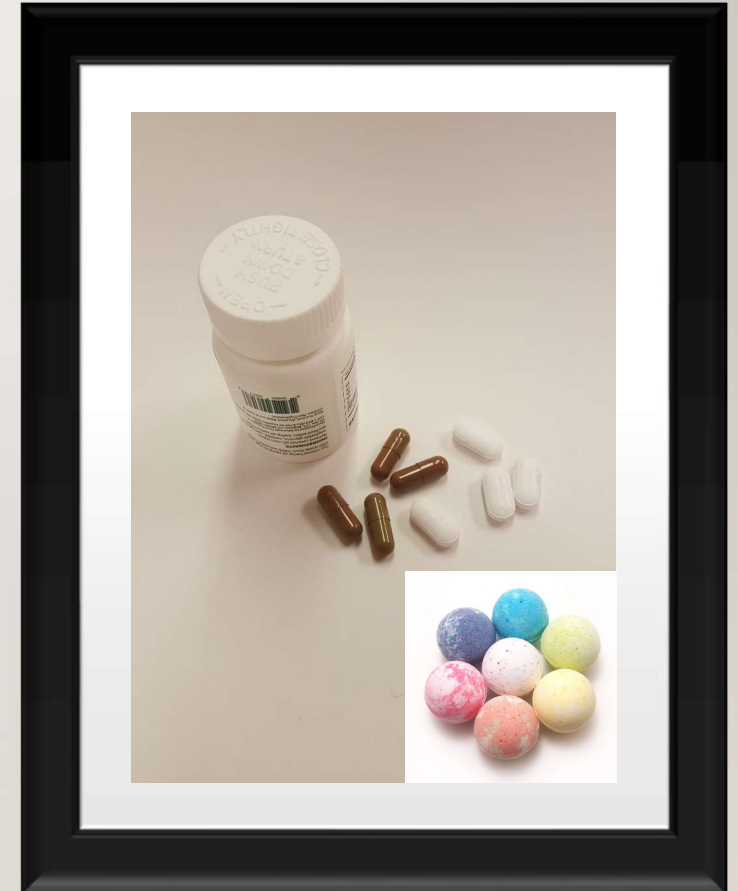

SOFTGEL



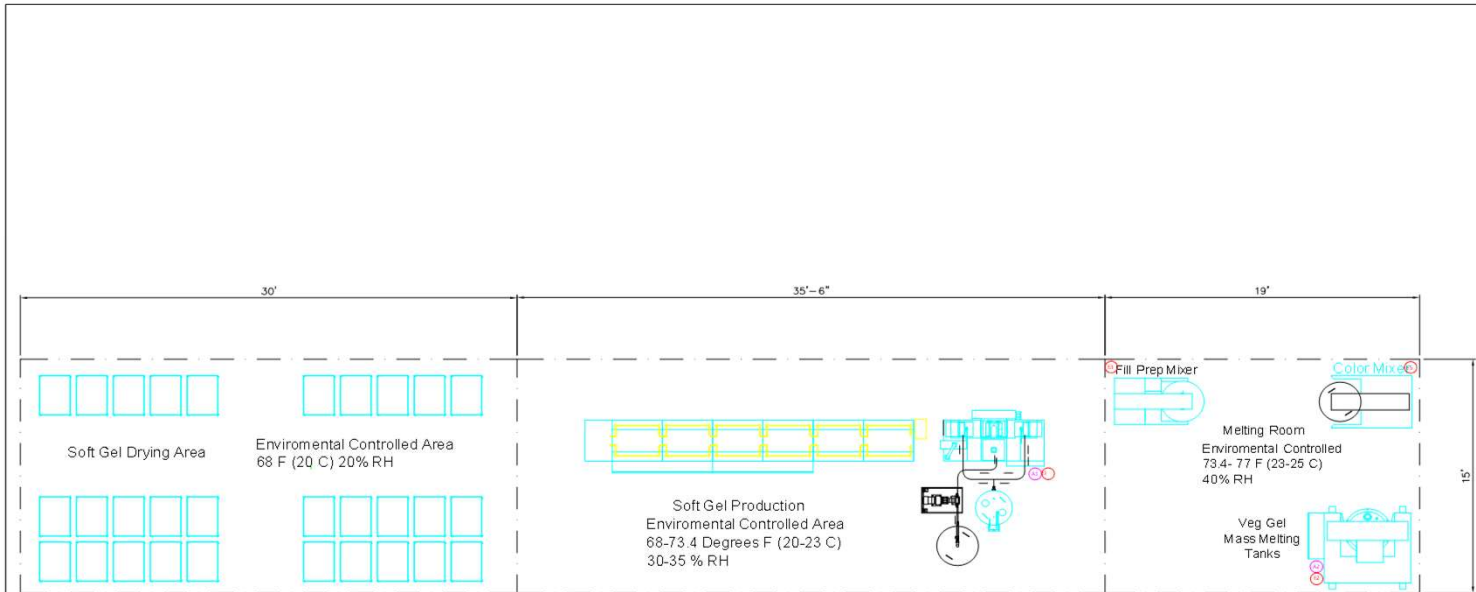

RIGHT STUFF EQUIPMENT

PROPRIETARY AND CONFIDENTIAL			NAME	DATE	MATERIAL	CUSTOMER	RRAVSTREBVG	SIZE	
THE INFORMATION CONTAINED IN THIS DRAWING IS THE SOLE PROPERTY OF RIGHT STUFF EQUIPMENT ANY REPRODUCTION IN PART OR AS A WHOLE WITHOUT THE WRITTEN PERMISSION OF RIGHT STUFF EQUIPMENT IS PROHIBITED.	DRAWN		BP	3/29/19	FINISH	NA	JOB NUMBER	NA	B
	CHECKED				UNITS	Inches	ASSEMBLY		REV
	Q.A.				TOLERANCE	1/32	DWG NUMBER	GB6 Softgel Production Layout	1
	SCALE		DO NOT SCALE DRAWING	LINEAR		PART NAME			
	SHEET	SHEET 1 OF 1	ANGULAR						

5

4

3

2

1





CAPSULES AND TABLETING





SEMI AUTO OR FULLY AUTOMATIC COUNTING & PACKAGING LINES



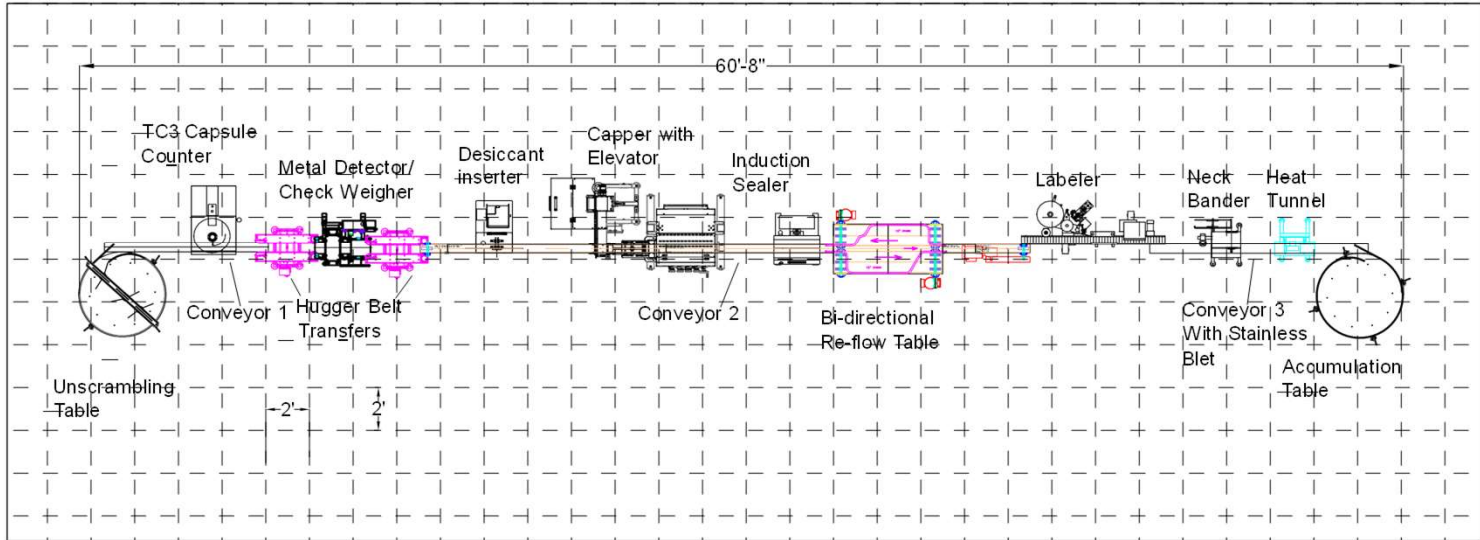

RIGHT STUFF EQUIPMENT

PROPRIETARY AND CONFIDENTIAL
 THE INFORMATION CONTAINED IN THIS DRAWING IS THE SOLE PROPERTY OF RIGHT STUFF EQUIPMENT ANY REPRODUCTION IN PART OR AS A WHOLE WITHOUT THE WRITTEN PERMISSION OF RIGHT STUFF EQUIPMENT IS PROHIBITED.



NAME	DATE	MATERIAL	NA	CUSTOMER	Dentomking Industries
DRAWN F.V.	08/15/2018	FINISH	NA	JOB NUMBER	FE463 NA
CHECKED		UNITS	Inches	ASSEMBLY	Capsule Line
Q.A.		TOLERANCE	1/32	DWG NUMBER	DC-TR-101100P
SCALE	DO NOT SCALE DRAWING	LINEAR		PART NAME	Draw1
SHEET	SHEET 1 OF 1	ANGULAR			

SIZE	B
REV	1

5

4

3

2

1





BLISTER PACKING.WET FILL & SOLID DOSE





MARKING, CODING, LABELING TABLE TOP LABELING OPTIONS

ALmatic C with thermal transfer printer





MARKING, CODING, LABELING PRINTING AND LABEL APPLICATION





MARKING, CODING, LABELING WRAP AROUND PRINT AND APPLY





MARKING, CODING, LABELING TUBE AND BOX LABELING





Electrical Requirements				
Drop	Equipment	Voltage	Amperage	Phase
E1	Adco Cartoner	230	3	3
E2	CVC 220 Labeler	120	20	1
E3	Accumulation Table	120	10	1

Air Requirements			
Drop	Equipment	Pressure [PSI]	CFM requirement
A1	Adco Cartoner	95	10
A2	Labeler	TBD	TBD

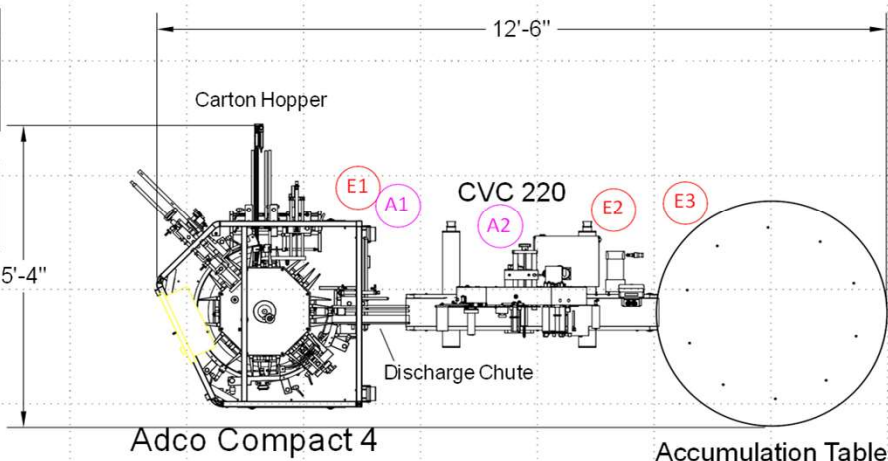

RIGHT STUFF EQUIPMENT

PROPRIETARY AND CONFIDENTIAL
 THE INFORMATION CONTAINED IN THIS DRAWING IS THE SOLE PROPERTY OF RIGHT STUFF EQUIPMENT. ANY REPRODUCTION IN PART OR AS A WHOLE WITHOUT THE WRITTEN PERMISSION OF RIGHT STUFF EQUIPMENT IS PROHIBITED.



NAME	DATE	MATERIAL	NA	CUSTOMER	XYZSORTE	SIZE
DRAWN F.V.	03/18/2019	FINISH	NA	JOB NUMBER	NA	B
CHECKED		UNITS	Inches	ASSEMBLY	CARTONER LINE	REV
Q.A.		TOLERANCE	1/32	DWG NUMBER	EGHYURQILK@hjulo_poui	1
SCALE	DO NOT SCALE DRAWING	LINEAR		PART NAME	CARTONER FLOOR SPACE	
SHEET	SHEET 1 OF 1	ANGULAR				

5

4

3

2

1





AUTOMATIC LABELING WRAP FOR ROUNDS- TOP DOWN FOR BOXES & TUBS





AUTOMATIC LABELING HORIZONTAL FOR TUBES-FRONT AND BACK



EDIBLES: CONFECTIONS.
DOSING, DEPOSITING,
MARKING AND CODING
WITH EDIBLE INKS LASER OR MOLDS

- Marking of edibles can be accomplished with a variety of coding systems.
- CIJ
- Laser
- Mold





EDIBLES

- Edibles: Bars and Baked Goods
- All Aspects for Food Manufacturing Systems
 - Bar Extrusion
 - Flow Wrapping
 - Coding and Labeling
 - Cartoning
 - Casing





INSPECTION FOR FOOD SAFETY

Metal Detection

Check Weigh

X-Ray





INTEGRATION AND INSTALLATION OF LINES OR ENTIRE PLANTS





CARTONING SEMI AND FULLY AUTOMATED SYSTEMS





The Association for Packaging and Processing Technologies

IN HOUSE DEMO ROOM AND ROBOTIC INTEGRATION CAPABILITIES





INTEGRATION CAPABILITIES INCLUDES OUR OWN PROGRAMMING AND PANEL BUILDS

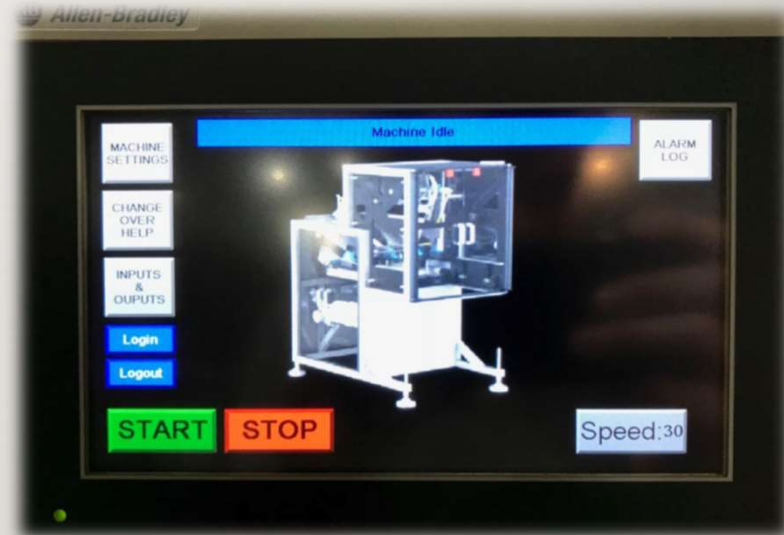



IN HOUSE LAB TO ASSIST UNDERSTANDING YOUR PRODUCTS

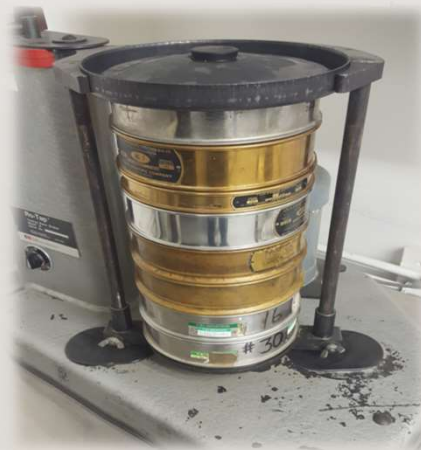



THE RIGHT STUFF EQUIPMENT EXPERIENCE

- Balanced Lines
- Turn Key Systems
- Best Return On Your Investment
- Reduced Reliance on Unskilled Workforce
- Get it Right the First Time
- Least Time to Efficient Production and Positive Cash Flow
- Margin Improvement along with Your Revenue Growth

